

- CSF 1 COARSE SEDIMENT FOREBAY
- CSF 2 COARSE SEDIMENT FOREBAY
- EP200 ENVIPOD 200 FILTER BY STORMWATER 360

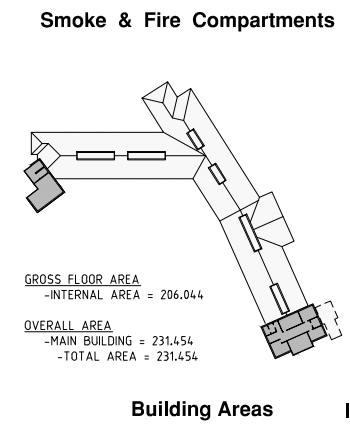
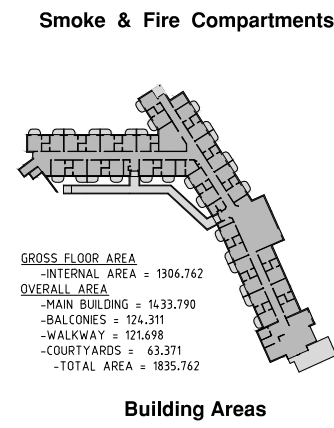
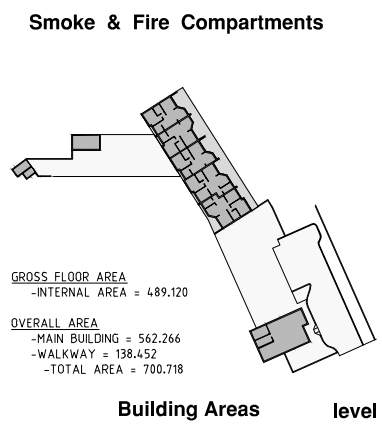
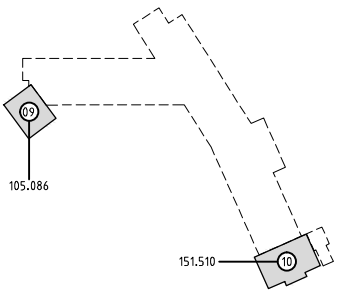
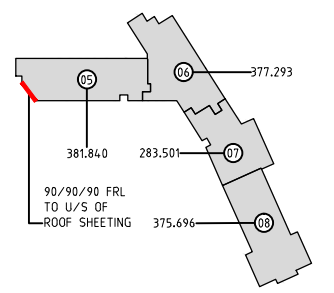
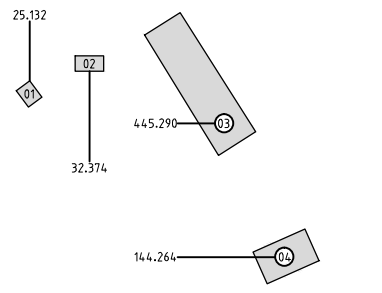
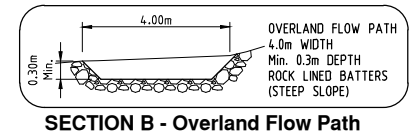
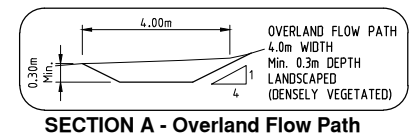
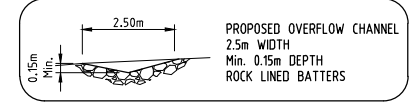
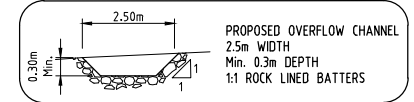

HOLDSWORTH

Site Plan
 Scale "B"

Preliminary

This drawing has been prepared by **OSBORN LANE** Consulting Engineers and must not be modified. Use of this information for any purpose must be done in conjunction with the hard copy approved drawings. Hard copy approved drawings take precedence over the electronic version and any discrepancies must be verified with **OSBORN LANE** Consulting Engineers. Do not rely on electronic drawing files for accurate set-out. All set-out information must be verified on site prior to commencement of fabrication and construction. The Builder / Contractor shall obtain and use the latest revision of all drawings associated with this drawing by this office and any relevant drawings / documents prepared by other consultants.



- NOTES**
- Contractor to verify all information & dimensions on site prior to commencement of construction.
 - DO NOT SCALE DRAWINGS
 - This drawing and the copyright thereof remains the property of **OSBORN LANE** Consulting Engineers A.B.N. 51 132 296 754.

Preliminary	06/12/2010	P/b
Issued for Dev. Approval	23/06/2010	P
Description:	Date:	Rev:

OSBORN LANE CONSULTING ENGINEERS

(Head Office)
 148A Palmerin St.
 Warwick Qld. 4370
 Ph 07 4660 3300
 Fax 07 4660 3310
 Email warwick@osbornlane.com

25 Warwick Road, Ipswich Qld. 4305
 Ph 07 3282 7770
 Fax 07 3281 7237

93 Musgrave Road, Red Hill Qld. 4059
 Ph 07 3510 8510
 Fax 07 3876 3045

PROPOSED UNIT DEVELOPMENT
 FOR
ROBERT RENTON
 AT
100 HOLDSWORTH ROAD,
NORTH IPSWICH.

SITE PLAN

drawn: R.B. / M.B.	date: OCTOBER 2009
checked: P/b	rev: P/b
scale: As Shown @ A1	job no: WK09-0412/P1
Sheet 01 of 10	